



Produktübersicht Basisprogramm



easyLine

einfach und doch solide

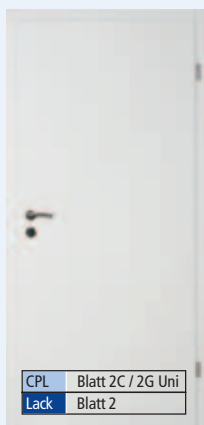

weiß



Esche weiß deckend

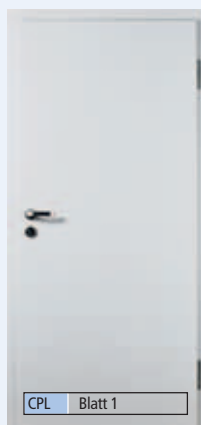

CePal Esche weiß offenporig

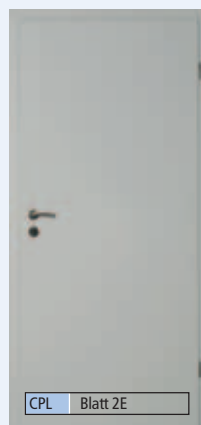

Uni grau



Stiltür weiß, 2 Füllungen

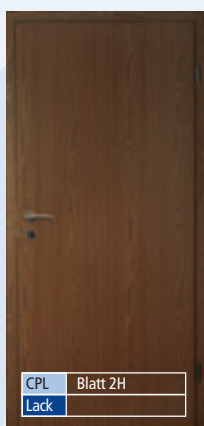

Nussbaum

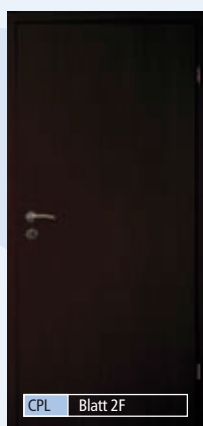

Eiche Espresso



Ahorn

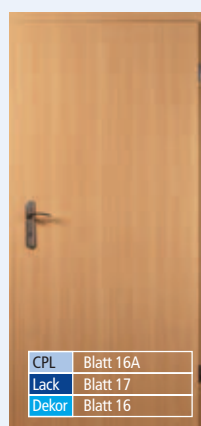

Buche



Stiltür weiß, gerade, geprägt



Kirsch



Eiche

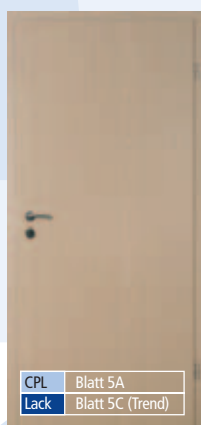

Eiche gekälkt

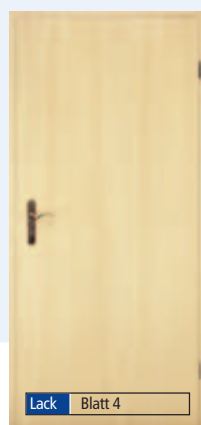

Limba

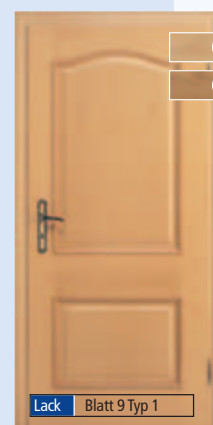

Stiltür Buche, abgeplattete Füllungen

classicLine

klassisches und zeitgemäßes Design



Lack Blatt 15A

Stiltür weiß, oben LA
unten Füllung



Lack Blatt 15B

Stiltür weiß, 4 Füllungen



Lack Blatt 15C

Stiltür weiß, oben 2 LA
unten 2 Füllungen



Lack Blatt 15H

Stiltür weiß, 3 Füllungen



Lack Blatt 15D

Stiltür weiß, 1 Füllung



Lack Blatt 14F

Stiltür weiß, gerade
geprägt, Sprosse 6F



Lack Blatt 14G

Stiltür weiß, gerade,
geprägt, 4 Felder



Lack Blatt 14G5

Stiltür weiß, gerade,
geprägt, oben 2 LA,
unten 2 Felder,



Lack Blatt 14A
Lack Blatt 14A5 (LA)
Lack Blatt 14B (Sprs.)

Stiltür weiß, Karniesbogen,
geprägt

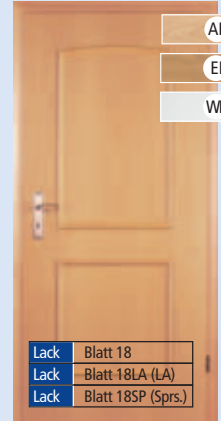

AH
EI
WL

Lack Blatt 18
Lack Blatt 18LA (LA)
Lack Blatt 18SP (Sprs.)

Stiltür Buche,
aufgesetzte Leisten



BU
EI

Lack Blatt 10 Typ 5

Stiltür Ahorn, abgeplattete
Füllung, oben Lichtauschnitt



BU
EI

Lack Blatt 10 Typ 4

Stiltür Ahorn, abgeplattete
Füllung, Sprosse 6 Felder

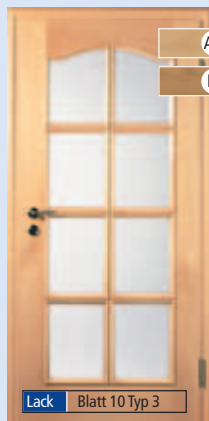

AH
EI

Lack Blatt 10 Typ 3

Stiltür Buche,
Sprosse 8 Felder

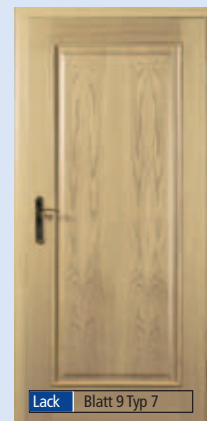

Lack Blatt 9 Typ 7

Stiltür Eiche,
1 abgeplattete Füllung



Lack Blatt 9 Typ 8

Stiltür Eiche,
2 abgeplattete Füllungen

highLine

stilvoll und besonders wertig



Designtür weiß Rille

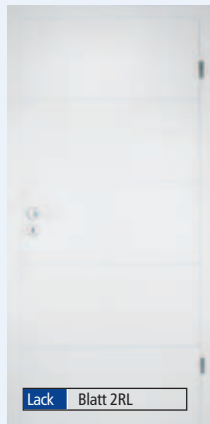

Designtür weiß Lisene



Designtür weiß
Exklusiv Dachprofil 1



Designtür weiß
Exklusiv Dachprofil



Designtür weiß Exklusiv,
Dachprofil grau



Designtür weiß,
aufgesetzt 2 Felder gerade



Designtür weiß,
aufgesetzt 2 Felder gerade,
Sprosse 6 Felder



Designtür weiß,
aufgesetzt 2 Felder gerade,
Sprosse 9 Felder



Designtür Ahorn
Hannover Exklusiv 1 Feld



Designtür Ahorn
Hannover Exklusiv 2 Felder

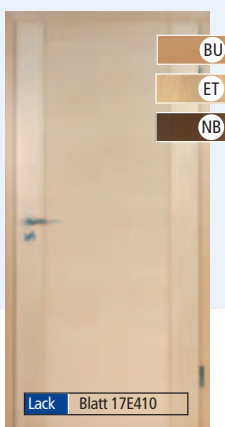

Designtür Ahorn
Aura 410

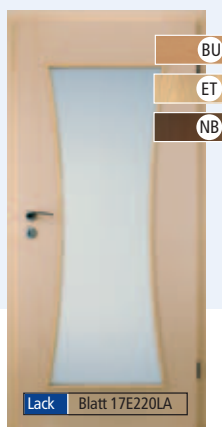

Designtür Ahorn
Aura 220 LA



Designtür Ahorn
LA 4 Edelstahl

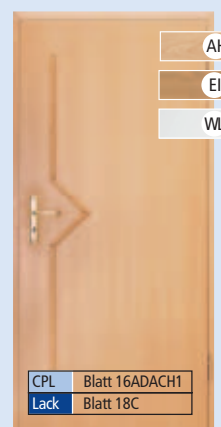

Designtür Buche
Dachprofil I

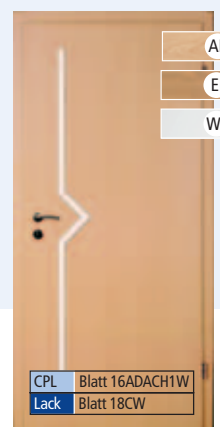

Designtür Buche,
Dachprofil I weiß



Designtür weiß, LA Motiv, Dachprofil grau



Designtür weiß, Raute



Designtür weiß, Raute, LA



Designtür weiß, Exklusiv, 4 LA mittig



Designtür weiß, Hannover Exklusiv, 1 Feld



Designtür, Ahorn, Hannover Exklusiv, 2 Felder, Sprosse 9F1



Designtür, Ahorn, Hannover Exklusiv, 2 Felder, Sprosse 9F2



Designtür, Ahorn, Hannover Exklusiv, 4 Felder



Designtür, Ahorn, Hannover Exklusiv, 4 Felder, 2 LA

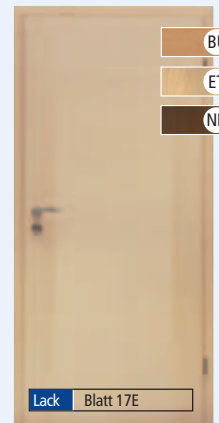

Designtür Ahorn aufrecht und quer farniert

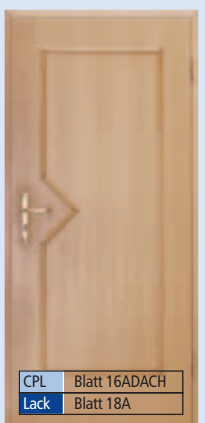

Designtür Buche Dachprofil



Designtür Buche Dachprofil LA Motiv



Designtür Buche Dachprofilstreifen LA Motiv

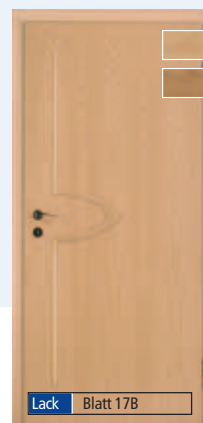

Designtür Buche Modell Rio I



Designtür Buche Modell Rio II



AH
EI

Lack Blatt 17C

Designtür Buche
Modell Rio II



AH
EI

Lack Blatt 17D

Designtür Buche
Modell Rio III, Motiv



AH
EI
WL

CPL Blatt 16A4LAR
Lack Blatt 174LAR

Designtür Buche,
4 LA rechts

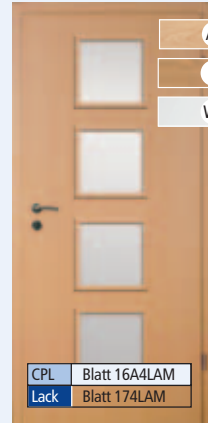

AH
EI
WL

CPL Blatt 16A4LAM
Lack Blatt 174LAM

Designtür Buche,
4 LA mittig



Aachen



AH
EI
WL

CPL Blatt 16A5LARAUTE
Lack Blatt 175LARAUTE

Designtür Buche, 5 LA,
Raute



AH
EI
WL

CPL Blatt 16A9LAM
Lack Blatt 179LAM

Designtür Buche,
9 LA

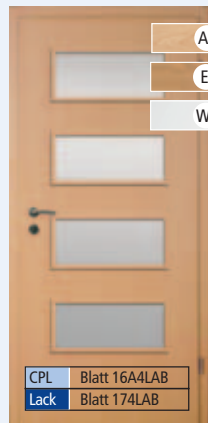

AH
EI
WL

CPL Blatt 16A4LAB
Lack Blatt 174LAB

Designtür Buche,
4 LA, breit

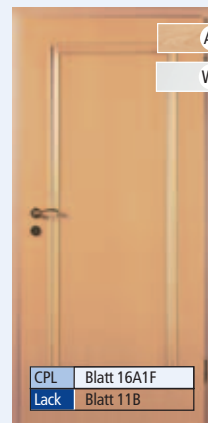

AH
WL

CPL Blatt 16A1F
Lack Blatt 11B

Designtür Buche,
Hannover Exklusiv,
1 Feld

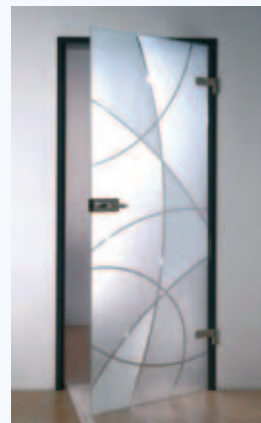

Melbourne



AH
WL

CPL Blatt 16A1FLA
Lack Blatt 11C

Designtür Buche
Hannover Exklusiv,
1 Feld

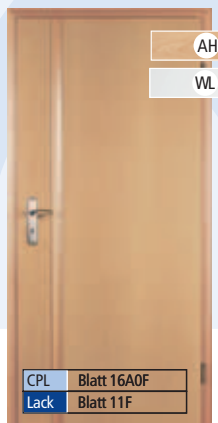

AH
WL

CPL Blatt 16A0F
Lack Blatt 11F

Designtür Buche
Hannover 1 Exklusiv

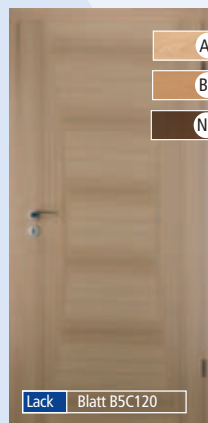

AH
BU
NB

Lack Blatt B5C120

Designtür Eiche Trend
Aura 120

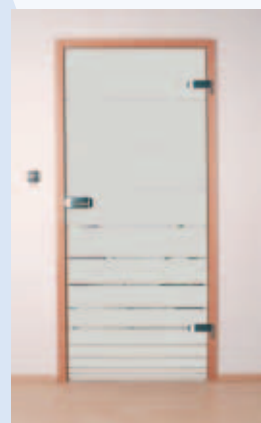

Striscio

Ganzglas- und Holzglastüren

für Raumerlebnisse mit Durchblick

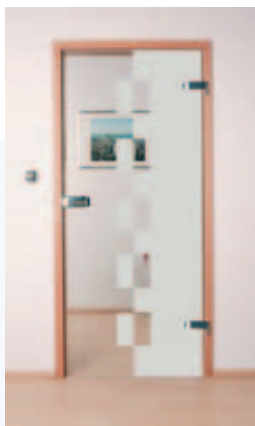

Bari Mattierung



Bari Siebdruck



Catania

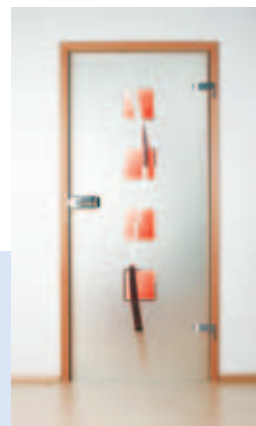

Catania mit Lackierung



Vier Jahreszeiten



Offenbach

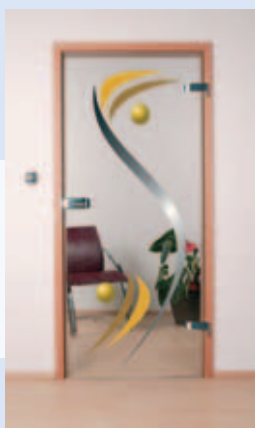

Oslo

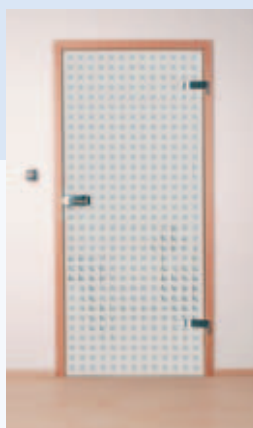

Quattro



Salzburg



Sempre mit
4 Holzapplikationen Buche

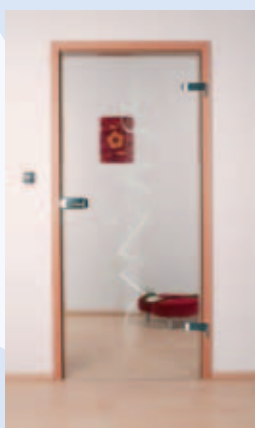

Termoli

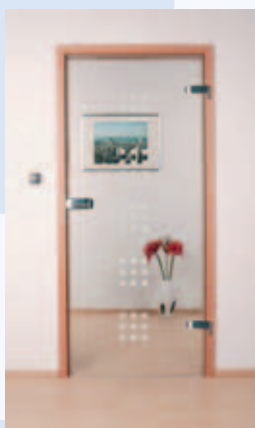

Tirano

Informationen zu Beschaffenheit und Erstellung
von Motiven und Schmuckelementen
finden Sie auf der Info-Seite 15.

AluPorte und PaloPorte

stilvoll und funktional



1 flg, 2 Sprossen, matt

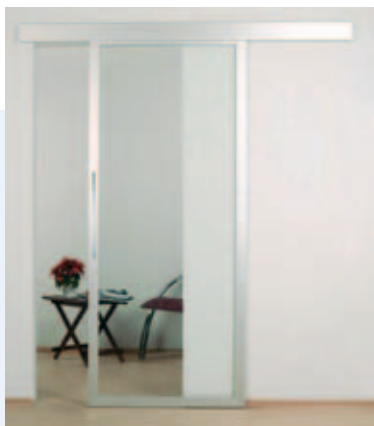

1 flg, klar

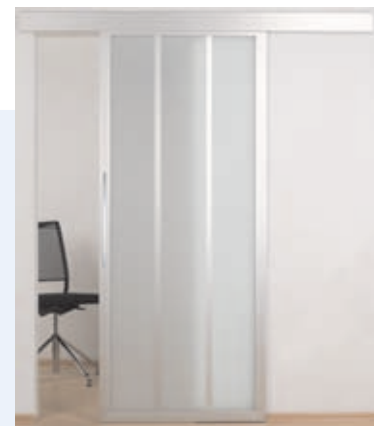

1 flg, matt



2 flg, matt



4 flg, 2 Sprossen, matt, Holzfüllung



1 flg, 3 Alusprossen, matt-klar



1 flg, 3 Sprossen, matt, grün

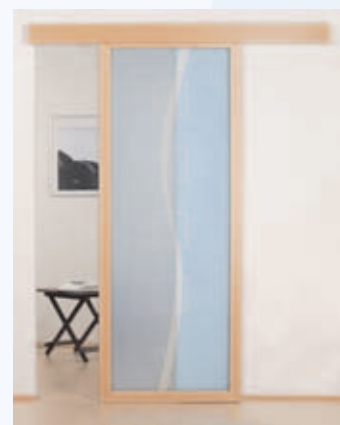

1 flg, Nivana blau

Massivtüren

Qualität durch und durch



2flg, 3 Sprossen, matt



3 flg, matt



Ahorn, 2 Füllungen

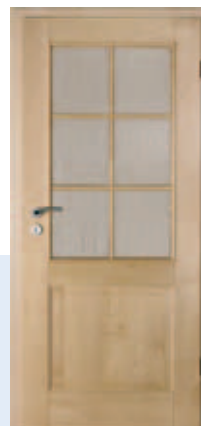

Ahorn, 2 Füllungen,
oben Sprosse 6F



Birke, 2 Füllungen

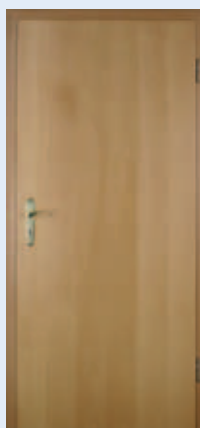

Buche, glatt



Eiche, 2 Füllungen,
2 Schweifbögen

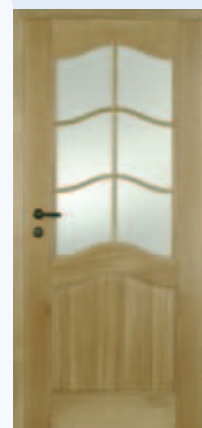

Eiche, 2 Füllungen,
2 Schweifbögen, Spr. 6F



Eiche AD1



Fichte, 1 Füllung

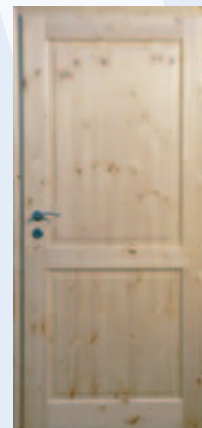

Kiefer, 2 Füllungen



Fichte, 4 Füllungen,
2 x Lichtausschnitt



Fichte, gebürstet,
3 Füllungen



Fichte, gebürstet, weiß,
2 Füllungen, Segmentbogen



Blatt 21 M 303

Designtür, weiß,
HT-Finish, Modell 303



Blatt 24 MC 3

Designtür, weiß, HT-Finish
Modell Charisma 3



Kirsche, 2 Füllungen,
oben LA, Sonderglas

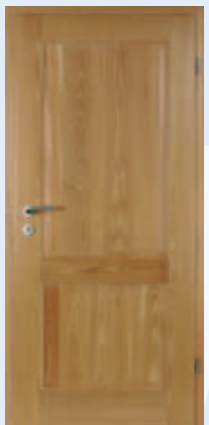

Lärche, 2 Füllungen



AH



BI



BU



EI



ES



FI



HE



KIE



KI



LÄ



Blatt 21 M 105

Designtür, Ahorn,
HT-Finish, Modell 105

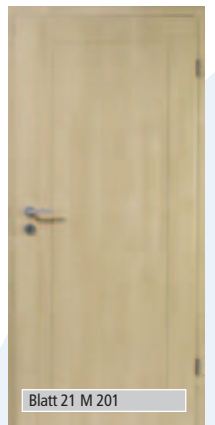

Blatt 21 M 201

Designtür, Ahorn,
HT-Finish, Modell 201

Lack Blatt 30

Alle Massivholz-Türen
sind lackiert und stehen
in nebenstehenden Holzarten
zur Auswahl...



Buche Thermo,
2 Füllungen A



Blatt 23

Designtür, Eiche, HT-Finish,
Modell Sylt, LA Glas



Blatt 21 M 302

Designtür, Erle,
HT-Finish, Modell 302

Thermolaminat

hoch beanspruchbar und De signauswahl



Designtür, weiß, HT-Finish
Modell Charisma 4 LA



Designtür, weiß, HT-Finish
Modell Charisma 6



Designtür, weiß, HT-Finish
Modell Elba, Sprosse 6 F



Designtür, weiß, HT-Finish
Modell Rügen, oben LA



Designtür, weiß, HT-Finish
Modell Sylt, oben LA



Designtür, Ahorn,
HT-Finish, Modell 301



Designtür, Ahorn,
HT-Finish, Modell 304



Designtür, Ahorn,
HT-Finish, Modell 305



Designtür, Ahorn,
HT-Finish, Modell 306

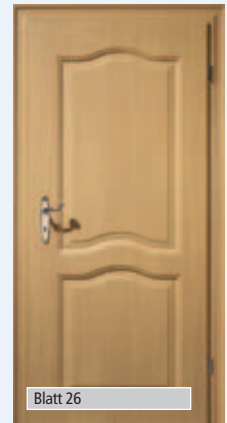

Designtür, Buche, HT-Finish
Modell Elba

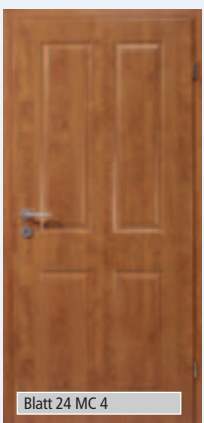

Designtür, Kirschbaum,
HT-Finish, Modell Charisma 4



Designtür, Kirschbaum,
HT-Finish, Modell Kreativo

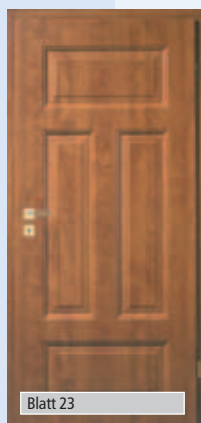

Designtür, Kirschbaum,
HT-Finish, Modell Sylt

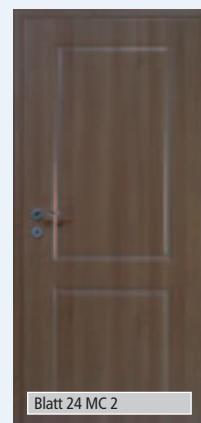

Designtür, Nussbaum,
HT-Finish, Modell Charisma 2

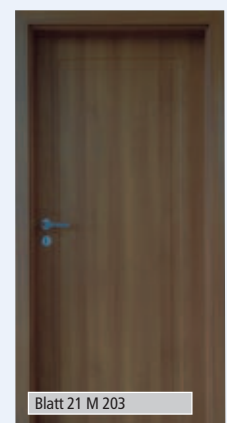

Designtür, Nussbaum,
HT-Finish, Modell 201



Blatt 23

Designtür, Nussbaum, HT-Finish, Modell Sylt LA

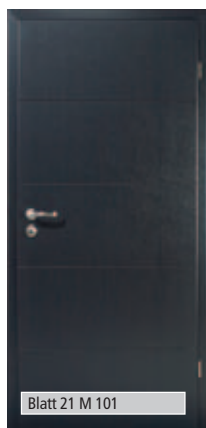

Blatt 21 M 101

Designtür, Wenge, HT-Finish, Modell 101

Alle Thermolaminat-Türen stehen in folgenden Dekoren zur Auswahl:



AH



BU



EI



ER



ES



KI



NB



WS



WE

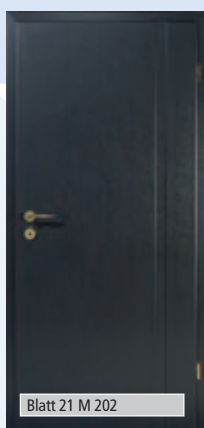

Blatt 21 M 202

Designtür, Wenge, HT-Finish, Modell 202



Blatt 24 MC 4Q

Designtür, Wenge, HT-Finish, Modell Charisma 4Q



Blatt 24 MC 2

Designtür, Wenge, HT-Finish, Modell Charisma 2



Raumspartür, HT-Finish, Modell 103

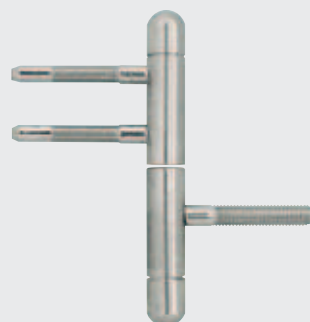

Band, 2teilig, vernickelt, Rundkopf

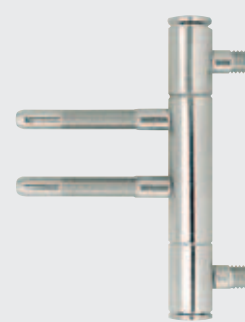

Band, 3teilig, vernickelt, gerade



Band, 2teilig, vergoldet, gerade



Band, 3teilig, vergoldet, gerade

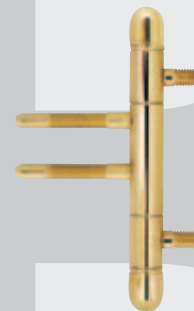

Band, 3teilig, vergoldet, Rundkopf

Bänder und Schlösser

Beständige Verbindungen

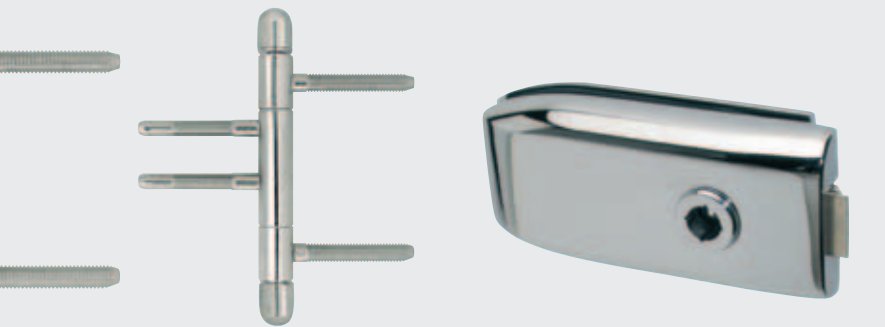

Band, 3teilig, vernickelt, Rundkopf



Schlosskasten, GGT, Chrom

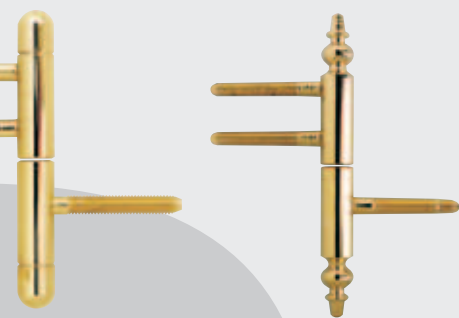

Band, 2teilig, vergoldet, Rundkopf

Band, 2teilig, vergoldet, Stilzierkopf



Schlosskasten, GGT, Messing poliert

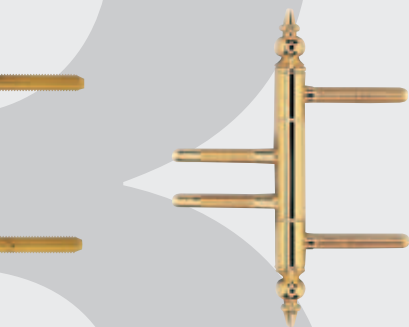

Band, 3teilig, vergoldet, Stilzierkopf



Schlosskasten, GGT, Nickel matt auch in Edelstahl lieferbar

Abbildungen ähnlich

Schließsysteme

Öffnen und Schließen



Aluminium Modell Philipp



Aluminium Schutzbeschlag



Messing poliert Modell Dana 1



Nickel matt Modell Dana 2



Edelstahl Modell Stella



Edelstahl Schutzbeschlag

Schließsysteme

Türen stilvoll öffnen und schließen

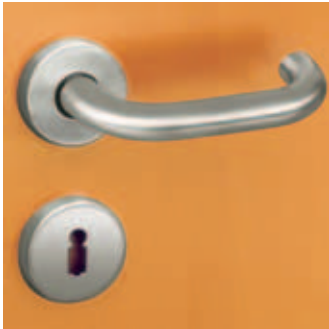

Edelstahl Modell Wedemark,
in Alu, Modell Nadine



Edelstahl poliert/matt Modell Christina



Chrom/Perla Silbermatt Modell Luna 4



Chrom/Perla
Silbermatt Raffaello



Chrom/Chrom matt Modell Luna 2



Chrom/Chrom matt Modell Lotus 1



Edelstahl Modell Riva



Chrom/Chrom matt
Modell Futura 2



Edelstahl Modell Euro



Messing poliert
Modell Malaga Rosette



Messing poliert
Modell Malaga Langschild



Messing poliert /matt
Modell Luna 2

Info-Seiten

Wissenwertes rund um Ihre Wunschtüren

Übersicht Zargen

Mögliche Kombinationen von Oberfläche und Bekleidungsform

Oberfläche	1. Glatt	2. Profil	3. Stil	4. Royal	5. Brianzo
Can. Ahorn Lack	•	•	•	•	•
Buche Lack	•	•	•	•	•
Eiche Lack	•	•	•		•
Eiche Trend Lack	•				
Limba Lack	•				
Sapeli Lack	•				
Nussbaum Lack	•			•	
Weiß Lack	•	•	•	•	•
Alle CPL-Dekore	•			•	
Alle CePal-Dekore	•			•	
Ahorn, Buche Deko	•				

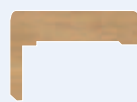

Glatt 50, 60 mm bzw. 72 mm



Profil Bekl.-Breite 72 mm



Stil Bekl.-Breite 72 mm

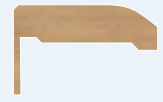

Royal Bekl.-Breite 70 bzw. 75 mm



Edelstahl Modell Topline, in Alu, Modell Marie

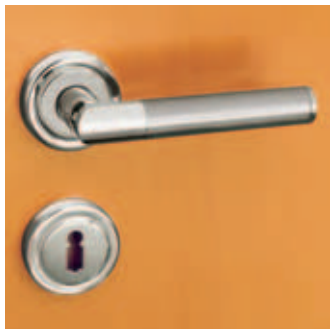

Chrom/Chrom matt Modell Steffen



Edelstahl Modell Futura 1 auch in Nickel matt lieferbar

Alle lieferbaren Lack- und CPL-Dekore

CPL Lack AH Ahorn	CPL Lack KI Kirsche	CPL WS Weiß Uni	Lack ES Esche
CPL Lack BU Buche	CPL Lack NB Nussbaum	CPL GR Grau Uni	Lack HE Hemlock
CPL Lack EI Eiche	CPL Lack WL Weiß-Lack	CPL EG Eiche gekälkt	Lack KIE Kiefer
CPL Lack ER Erle	Lack SA Sapeli	Lack EE Eiche Espresso	Lack ET Eiche Trend
CPL Lack EW Esche weiß	Lack LÄ Lärche	Lack BI Birke	Lack LI Limba

Siebdruck-Türen

Ein Rastersieb wird über die Glasscheibe gelegt und Keramiklack durch die Öffnungen im Fasergewebe gedrückt. Hierdurch entsteht das gewünschte Motiv auf der Scheibe. Diese so bedruckten Glasscheiben werden getrocknet und danach in einem Vorspannofen bei einer Temperatur über 600°C gebrannt. Hierbei verschmilzt der Lack mit der Glasfläche und bildet eine permanente und dauerhafte Oberfläche. Bei mehrfarbigen Objekten wird dieser Vorgang für jede Farbe wiederholt. Der Wärm- und Abkühlprozess gibt dem einbrennlackierten Glas gleichzeitig Sicherheitsglaseigenschaften (ESG).

Rillenschliff-Türen

Das Motiv wird im Schleifautomaten auf die Glasscheibe geschliffen. Je nach der Art des Motivs wird ein V-Rillenschliff (symmetrische Rille), ein Offcenter-Rillenschliff (asymmetrische Rille) oder ein Konkav-Rillenschliff (halbkreisförmige Rille) verwendet.

Mattierte Türen

Das Motiv wird mit Hilfe von Sandstrahltechnik auf die Glasscheibe gebracht. Diese Technik verleiht der Glastür eine dezente Eleganz. Die Oberflächen können ein- oder beidseitig behandelt werden. Die Oberflächen werden danach zum Schutz mit einer Versiegelung behandelt.

Diese Methoden zum Erzeugen von Motiven auf Glasscheiben können untereinander kombiniert werden und ergeben dann eine besonders brillante Optik.

HENSEL®



Herzlich willkommen...

Öffnungszeiten der HENSEL Türen-Galerie:

Montag bis Freitag von 7 - 18 Uhr

Samstag von 10 - 16 Uhr

Schlager Chaussee 1 · 30900 Wedemark · Telefon 05130-9789-18

eMail: galerie@hensel-innentueren.de · www.hensel-innentueren.de

Ihr HENSEL-Profi-Partner